

DESCRIPTION

PD (Powered Device) Integrated Module (Isolation Type)

FEATURES

- Fully IEEE 802.3af compliant
- 12.95 watt output load
- IEEE Power class programmable (Green)
- 1500 Volt DC isolation (Input to Output)
- 5V, 12V ,24V DC output voltage models
- Compact package minimum PCB footprint
- Minimal external components required
- Overload and short circuit protection
- Wide input voltage (36V to 57V DC)
- Adjustable output voltage
- Support PoE applications in both of Fast / Gigabit Ethernet environments.
- Low output ripple and noise
- Low cost

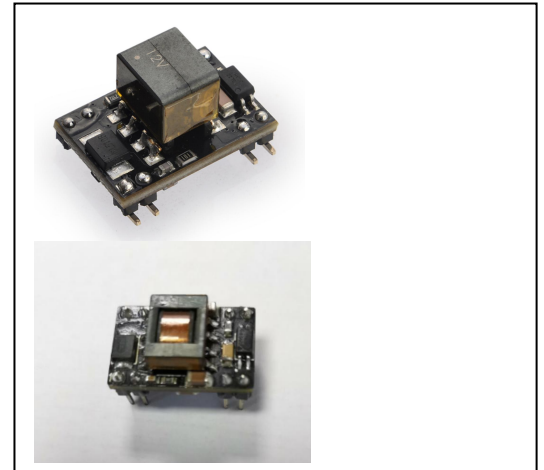

APPLICATION AREAS

- Security and alarm systems
- Voice over IP phones
- Access control systems
- IP Cameras
- Displays, Net Monitors
- Public address systems
- Wireless access points
- Environmental control
- Telemetry
- Remote environmental monitoring

1 Product Overview

1.1 DP9900 Product Selector

Part Number	Nominal Output Voltage	Output Power	
		70°C	85°C
DP9905M	5.0V	9 Watts	6 Watts
DP9912M	12.0V	12 Watts	9 Watts
DP9924M	24.0V	12 Watts	11 Watts
DP9905LP	5.0V	7 Watts	4.5 Watts
DP9912LP	12.0V	10 Watts	6 Watts

Table 1: Ordering Information

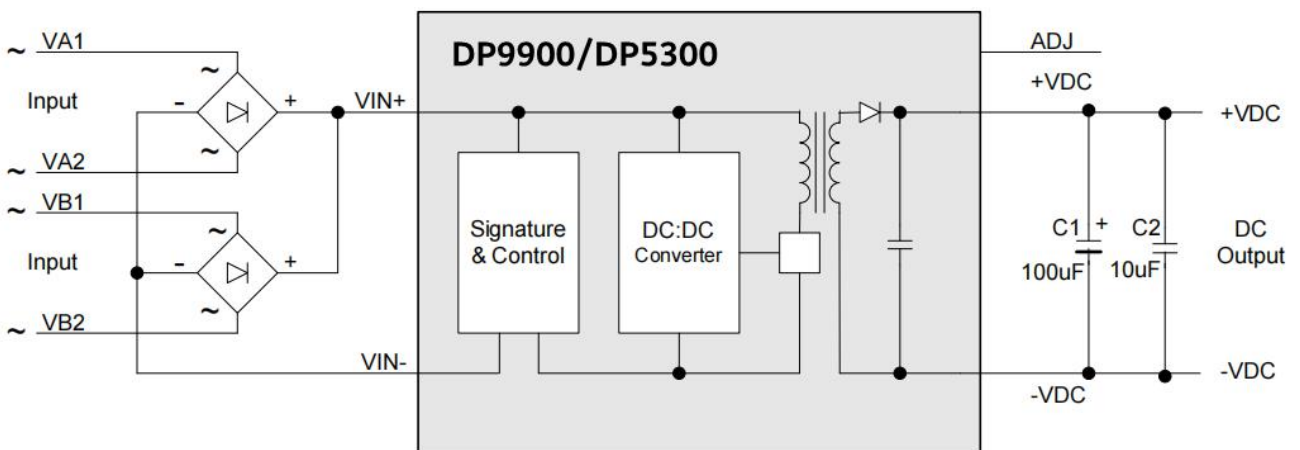

Figure 1: Block Diagram

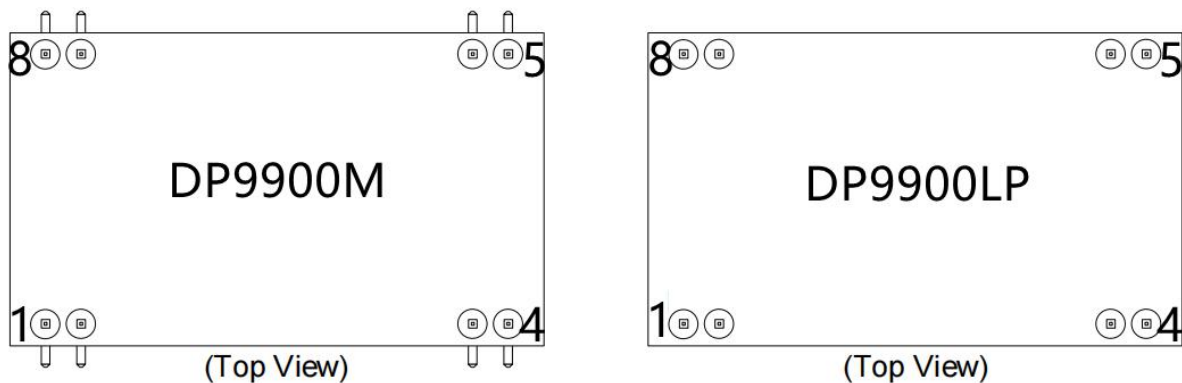

Figure 2: DP9900 Package Format

1.2 Pin Description

Pin #	Name	Description
1	+VDC	DC Output. This pin provides the regulated output from the DC/DC converter.
2		
3	-VDC	DC Return. This pin is the return path for the +VDC output.
4	ADJ	Output Adjust. The output voltage can be adjusted from its nominal value, by connecting an external resistor from this pin to either the +VDC pin or the -VDC pin.
5	VIN+	Direct Input +. This pin connects to the positive (+) output of the input bridge rectifiers.
6		
7	VIN-	Direct Input -. This pin connects to the negative (-) output of the input bridge rectifiers.
8		

Table 2: Pin Description

2 Functional Description

2.1 Typical Connections

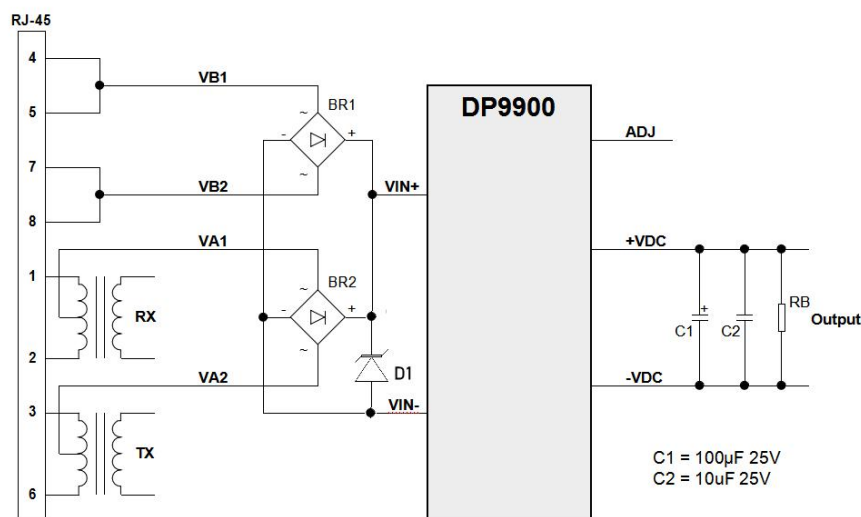

Figure 3: Typical Connection Diagram

BR1, BR2=MB6S; D1=SMAJ58A; RB= \geq I Load min

2.2 Output Voltage Adjustment

The DP9900 series has an OADJ pin, which allows the output voltage to be increased or decreased. Figure 4 shows how the ADJ pin is connected.

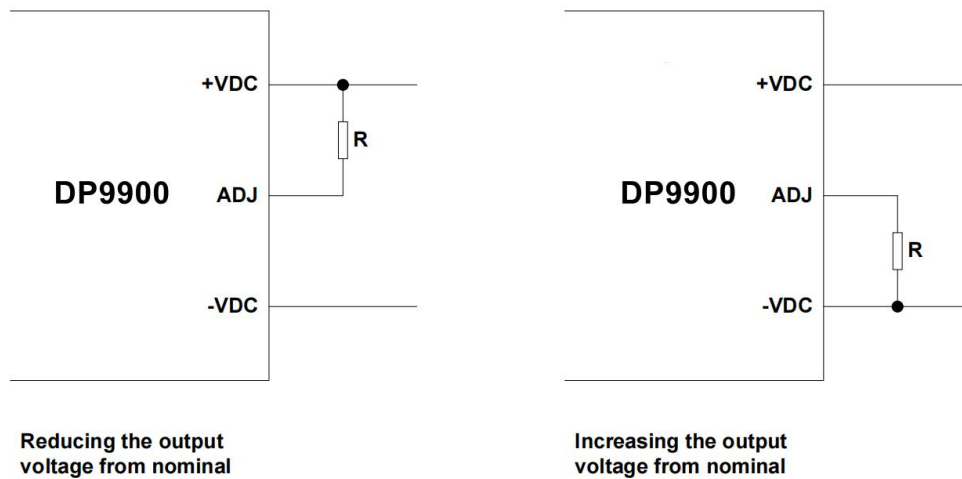

Figure 4: Output Adjustment

Reducing the output voltage, connect R between ADJ and +VDC			
Value of R	DP9905 output	DP9912 Output	DP9924 Output
Open Circuit	5.00V	12.07V	23.93V
0 Ohms	4.48V	10.0V	19.85V
100K	4.76V	11.15V	21.85V
470k	4.92V	11.76V	23.23V
Increasing the output voltage, connect R between ADJ and -VDC			
Value of R	DP9905 output	DP9912 output	DP9924 Output
Open Circuit	5.00V	12.07V	23.93V
0 Ohms	5.66V	12.75V	24.6V
100K	5.27V	12.34V	24.2V
470k	5.08V	12.16V	24.01V

Table 3: Output Adjustment Resistor (R) Value

3 Electrical Characteristics

3.1 Absolute Maximum Ratings

	Parameter	Symbol	Min	Max	Units
1	DC Supply Voltage	V _{CC}	-0.3	60	V
2	DC Supply Voltage Surge for 1ms	V _{SURGE}	-0.6	80	V
3	Storage Temperature	T _S	-40	+100	°C

3.2 Recommended Operating Conditions

	Parameter	Min	Typ	Max	Units
1	Input Supply Voltage	36	48	57	V
2	Under Voltage Lockout	30		36	V
3	Input Current		350	400	mA
4	Operating Temperature	-40	25	85	°C
5	IEEE 802.3af	Class 0			

3.3 DC Electrical Characteristics

	DC Characteristic	Variant	Sym	Min	Typ ¹	Max	Units
1	Nominal Output Voltage	DP9924	+VDC	23.5	24	24.5	V
		DP9912		11.6	12	12.4	
		DP9905		4.75	5	5.25	
2	Minimum Load ²	DP9924	I _{LOAD}	20			mA
		DP9912		40			
		DP9905		100			

	DC Characteristic	Variant	Sym	Min	Typ ¹	Max	Units
3	Output Current (VIN = 48V)	DP9924M	I _{out}		0.5		A
		DP9912M			1.0		
		DP9912LP			0.8		
		DP9905M			1.8		
		DP9905LP			1.4		
4	Line Regulation	DP9924	V _{LINE}		0.15		%
		DP9912			0.05		
		DP9905			0.05		
5	Load Regulation – Min to Max (VIN = 48V)	DP9924	V _{LOAD}		0.15		%
		DP9912			0.1		
		DP9905			0.1		
6	Output Ripple and Noise _{5@} ^{Max load}	DP9924M	V _{RN}		TBD		mV _{p-p}
		DP9912M			146mV		
		DP9912LP			198mV		
		DP9905M			124mV		
		DP9905LP			TBD		
7	Peak Efficiency	DP9924M	EFF		87		%
		DP9912M			86		
		DP9912LP					
		DP9905M					
		DP9905LP					
8	Short-Circuit Duration ³		T _{SC}			∞	sec
9	Isolation Voltage (I/O) - Impulse Test		V _{ISO}			1500	V _{PK}

Note 1: Typical figures are at 25°C with a nominal 48V supply and are for design aid only. Not Guaranteed

Note 2: The module can emit an audible noise, if operated at less than the stated minimum I_{LOAD} and cause the PSE to fail its MPS.

Note 3: >200mohm short due to thermal limitation.

4 PackDPE

4.1 DP9900M

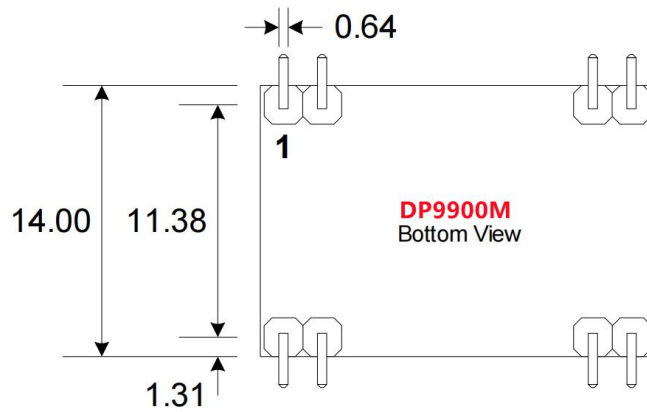
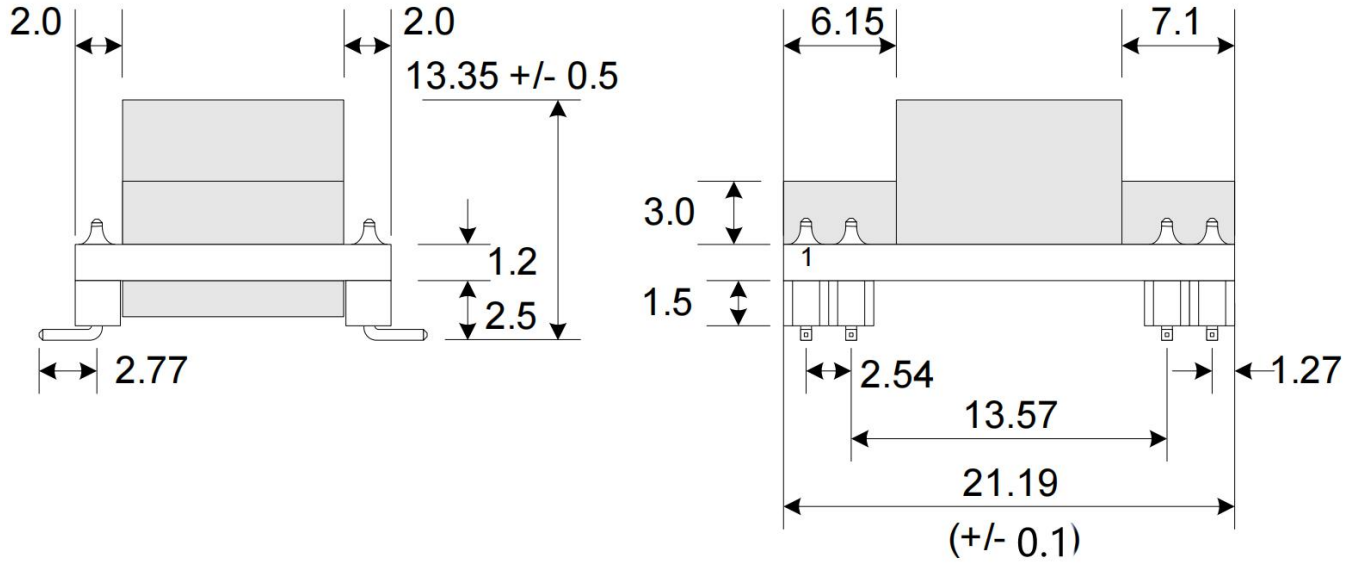

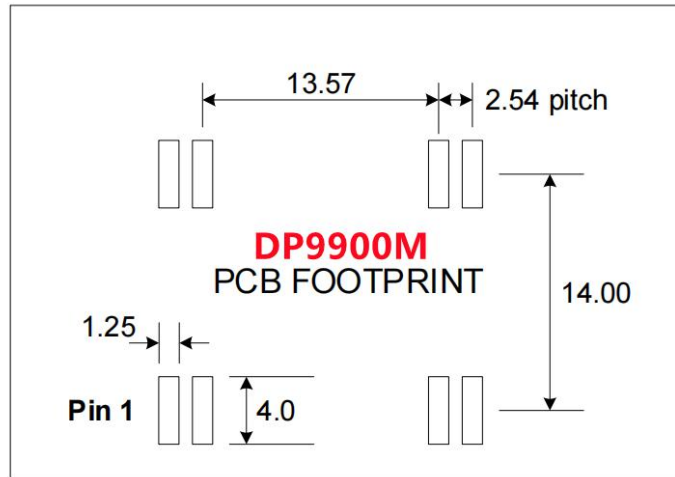

4.2 DP9900LP

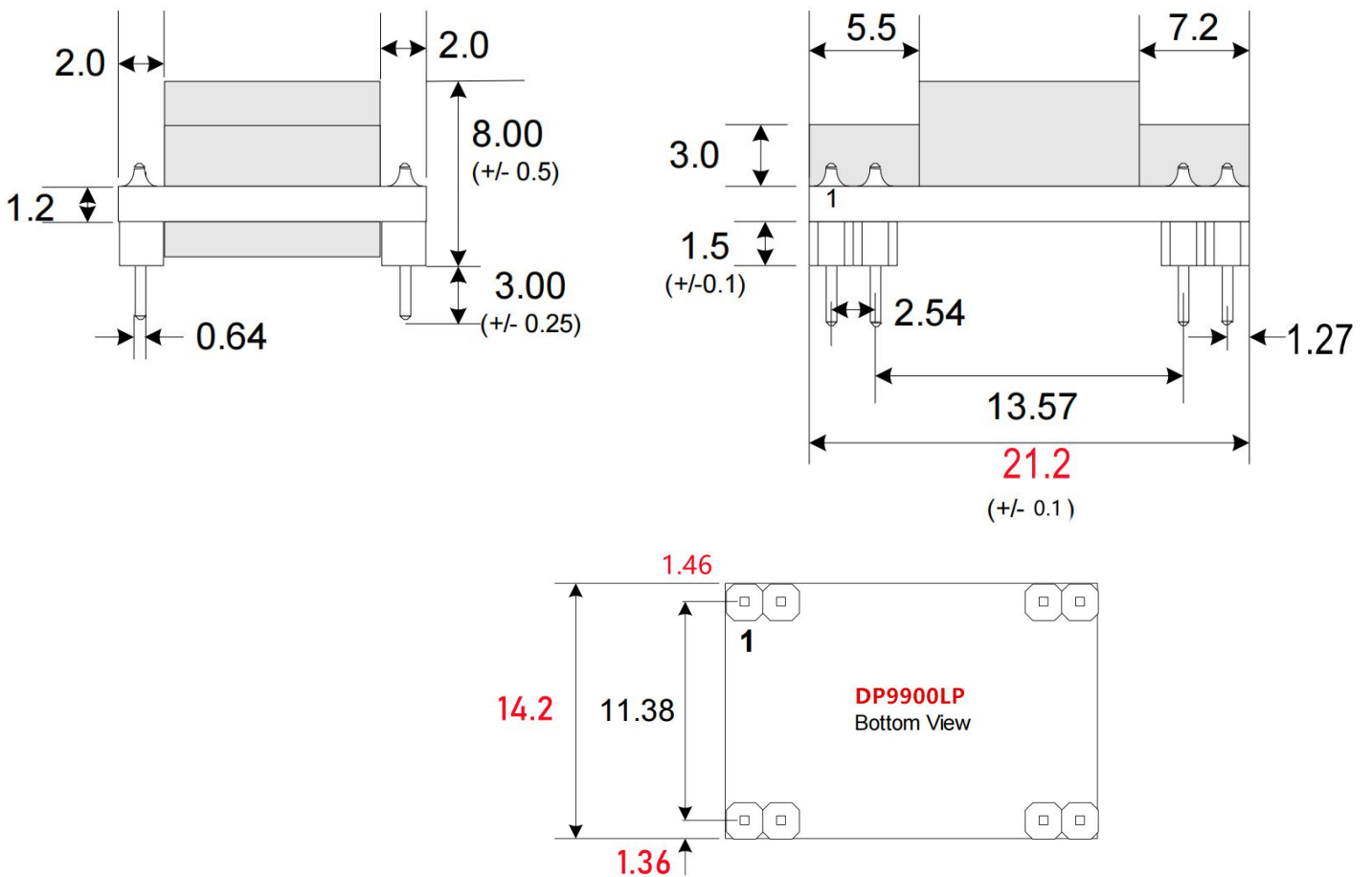

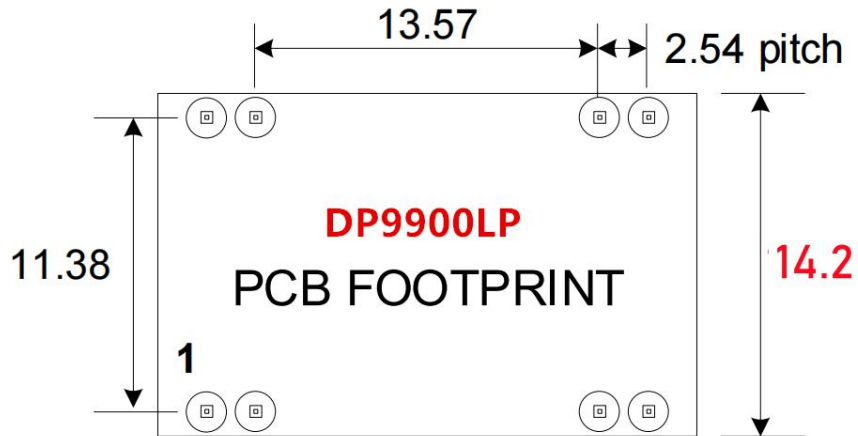

DP9912LP Test efficiency graph

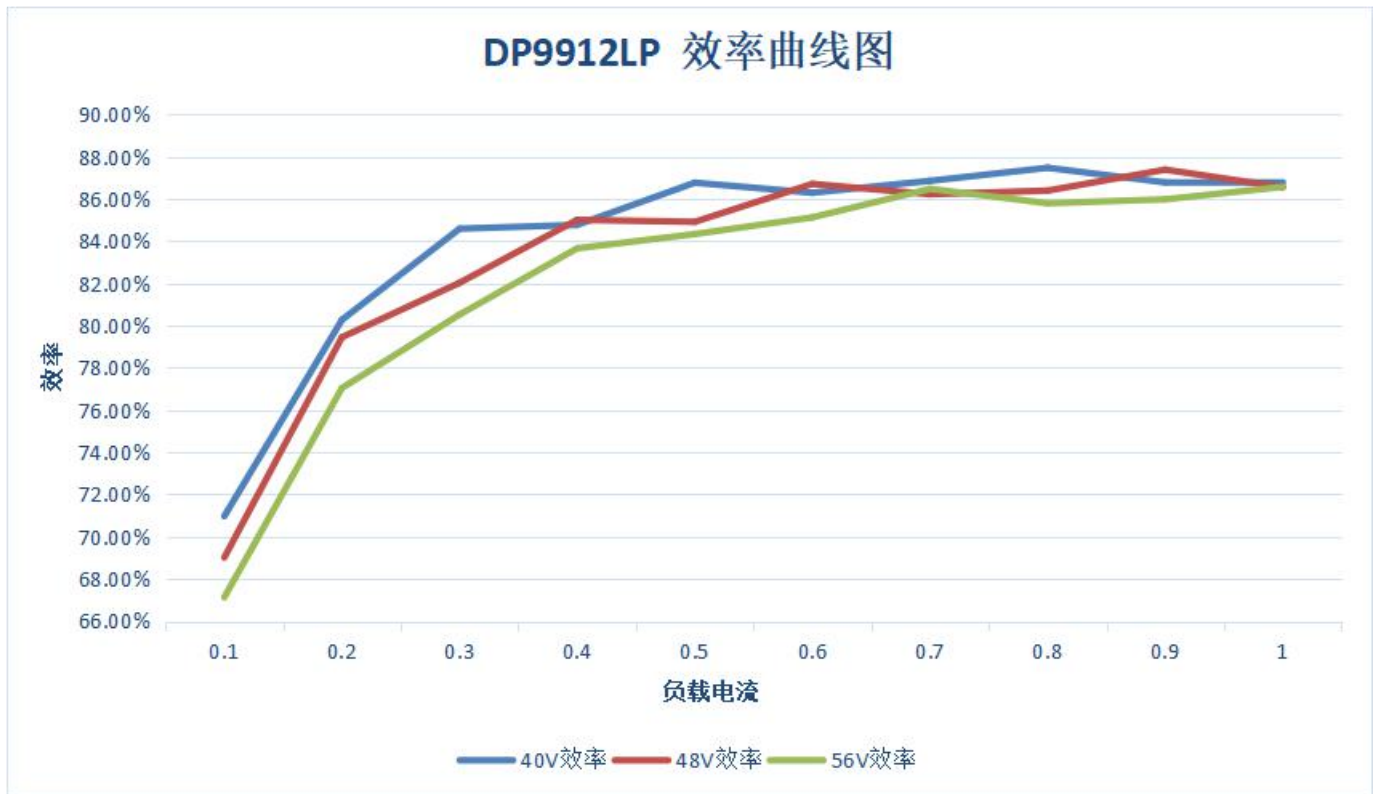

DP9912LP 56V The input test

Input voltage (V)	Input current (mA)	Load voltage (V)	Load current (A)	DC/DC efficiency
55.733	0.0052	12.084	0	0.00%
55.723	0.0323	12.083	0.1	67.13%
55.712	0.0563	12.083	0.2	77.05%
55.702	0.0808	12.081	0.3	80.53%
55.693	0.1037	12.08	0.4	83.67%
55.683	0.1286	12.079	0.5	84.34%
55.673	0.1529	12.078	0.6	85.13%
55.662	0.1756	12.076	0.7	86.48%
55.653	0.2023	12.075	0.8	85.80%
55.643	0.2271	12.073	0.9	85.99%
55.636	0.2506	12.071	1	86.58%

DP9912LP 48V The input test				
Input voltage (V)	Input current (mA)	Load voltage (V)	Load current (A)	DC/DC efficiency
48.372	0.0054	12.079	0	0.00%
48.358	0.0362	12.082	0.1	69.02%
48.347	0.0629	12.081	0.2	79.45%
48.334	0.0914	12.08	0.3	82.03%
48.323	0.1176	12.078	0.4	85.01%
48.311	0.1472	12.078	0.5	84.92%
48.301	0.173	12.077	0.6	86.72%
48.288	0.203	12.075	0.7	86.23%
48.276	0.2316	12.075	0.8	86.40%
48.265	0.2576	12.073	0.9	87.39%
48.252	0.289	12.071	1	86.56%

DP9912LP 40V The input test				
-----------------------------	--	--	--	--

Input voltage (V)	Input current (mA)	Load voltage (V)	Load current (A)	DC/DC efficiency
40.518	0.0058	12.066	0	0.00%
40.504	0.042	12.074	0.1	70.97%
40.492	0.0743	12.076	0.2	80.28%
40.481	0.1058	12.077	0.3	84.59%
40.471	0.1408	12.077	0.4	84.78%
40.458	0.172	12.077	0.5	86.78%
40.443	0.2076	12.076	0.6	86.30%
40.428	0.2407	12.075	0.7	86.86%
40.415	0.2732	12.074	0.8	87.48%
40.4	0.3099	12.073	0.9	86.79%
40.385	0.3445	12.071	1	86.76%